

Product Specifications

Product Name	Rice Ball Maker for Commercial Use
Machine Name	MULTI NIGIRI MAKER
Model Name	ASM575A
Power Source	AC110 - 120V, 50 / 60 Hz
Power Consumption	45 W
External Dimensions	Approx. W 14.2 in. x D 20.2 in. x H 28.4 in. Approx. W 360 mm ´ D 511.5 mm ´ H 720 mm * Excluding the Power Cord and protruding parts
Weight	Approx. 55.1 lbs. (25 kg.)
Production Capacity	Onigiri : 1300~1950 pcs./hour Sushi : 2600 pcs./hour Makunouchi : 1625~5200 pcs./hour <Note> Molding ability will vary depending on the roller.
Rice ball size	Rice ball sizes can be changed by switching Forming Rollers .
Hopper Capacity (Rice volume)	Maximum of approximately 22.0 lbs. (10 kg)
Forming Method	Helical mold forming method Roller forming method
Rice Feed Method	Automatic stirring (belt less) method
Fuse Capacity	2 amperes (A)
Power Cord	Grounding type Plug (9.8 ft. [3m] Cord)

External Diagrams

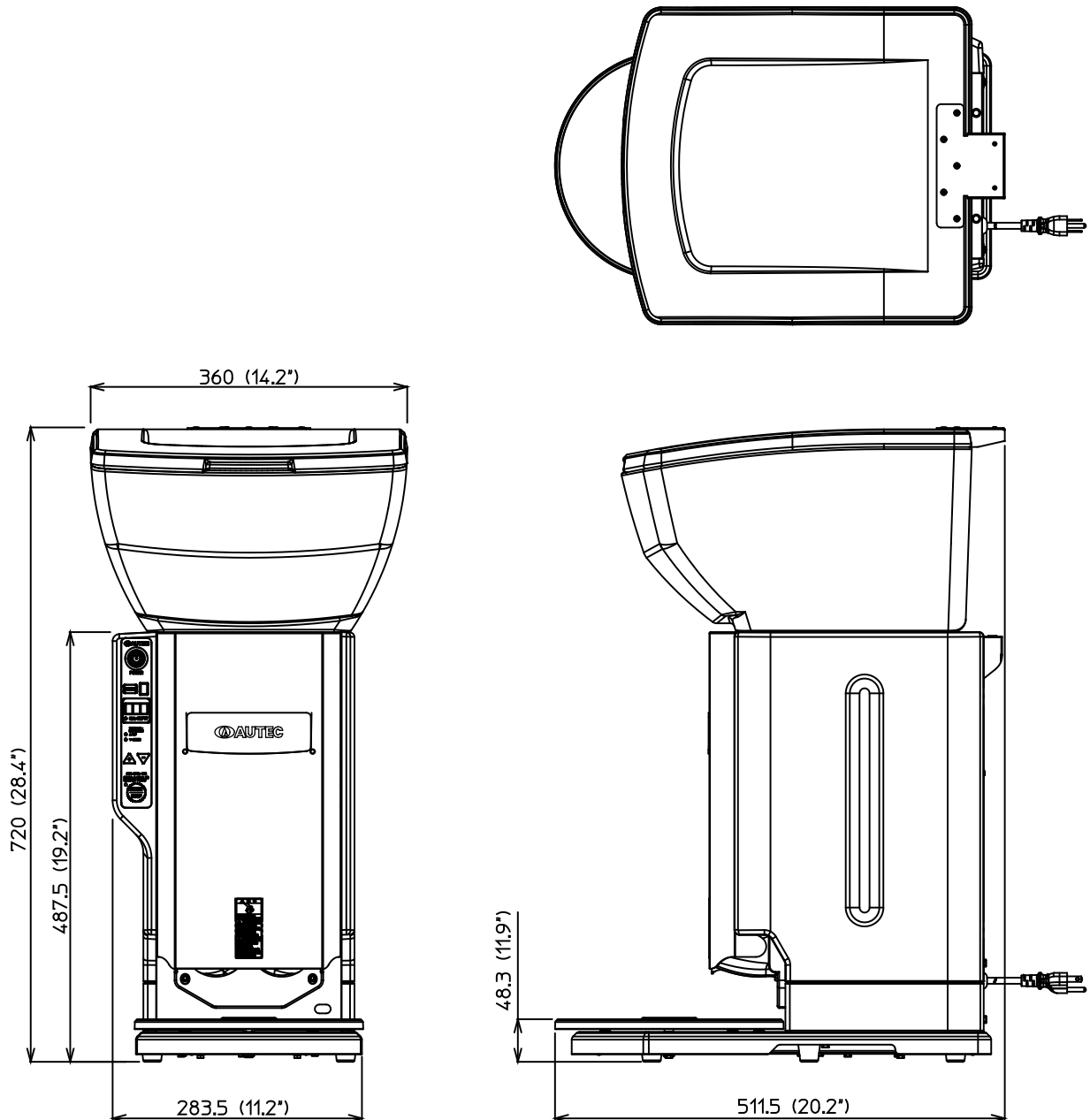

- Specifications and design of the machine are liable to change without prior notice for purposes of improvement.